



T 250 GT

ELECTROMECHANIC TURNSTILE

- Strong Mechanism
- Intense Usage
- Trouble-free Long Years
- Vandal-proof
- Reliable
- Spare Parts Support
- Indoor Conditions

T 250 GT ELECTROMECHANIC TURNSTILE

T 250 GT tripod turnstile provides the basic access control solution to secure various locations worldwide. The mechanism is designed and manufactured by MAKİM to ensure long years of trouble free use, especially for locations with intense passage flows.

Application

T 250 GT can be installed and used trouble-free in various locations like public transportation terminals, universities, banks, business centers, museums, sport centers and amusement parks etc.

Basic Materials

T 250 GT is produced in AISI 304 stainless steel. All arms and body are made of 304 stainless steel and the core is made of aluminum material. T 250 GT has stylish rounded legs. As an option, it can be produced from 316 stainless steel. The inner main mechanism of T 250 GT is produced in Makim manufactory with special investment casting technology, which makes the whole system a lot more robust and lasting. This ensures the system impact resistance and trouble-free operation for many years. The electronic boards are designed by the qualified engineers of Makim, enabling T 250 GT operate in various modes and integrations.

General Usage

T 250 GT electromechanic turnstile operates bidirectionally. Any kind of access control system like card reader, biometric reader, remote control unit or push button can be integrated to T 250 GT via simple dry-contact. Once the access right is granted, user should touch slightly to T 250 GT arm in order to make it rotate. T250 GT is automatically locked after the tripods complete one turn. If the user does not use the passage right in 15 seconds, T 250 GT will give buzzer warning and it will be locked. Status indicator LED lights are located on both sides of T 250 GT, in green arrow and red cross shape to show allowed passage directions. More than 30 people can be use the passage in 1 minute.

Safety

In case of power cut, T 250 GT is unlocked to allow free rotation of the arms in both sides. As an option, Makim can produce T 250 GT with drop-arm mechanism. With this mechanism turnstile received the signal from the emergency system and the broking arm is dropped to provide a completely free passage lane for quick evacuation of the area.

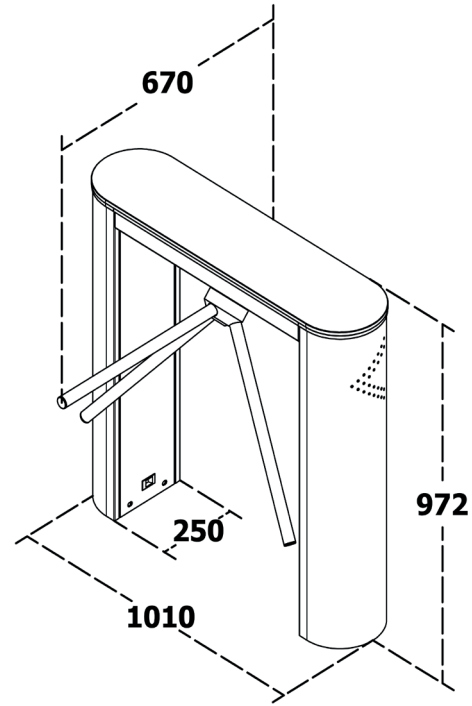

Control /Operation Voltage	100-230 VAC 50/60 Hz
Power Consumption	30 W
Operation Temperature	- 20° C - + 70° C With Optional Heater - 30° C
Passage Speed	30 P / Min.
Passage Range	Min. 42 cm / Max. 50 cm
Weight	40 Kg
Usage Area	Indoor
Optional Accessories	Drop-arm, remote control, button unit, card reader, biometric reader, counter
Top Cover	10 mm plexiglass, Op. 10 mm tempered glass
Protection	IP 42
Security Level	●●●●○